

# ELECTRICAL ENGINEERING INNOVATION COMPETITION & EXHIBITION 2025

## LIST OF EDITORS:

### FKE UITMCTKD

Mazratul Firdaus Mohd Zin  
Suziyani Rohafauzi  
Dayana Kamaruzaman  
Mohamad Taib Miskon  
Nur Idawati Md Enzai

### JKE PSMZA

Norfadhilah Hasan  
Nor Hasnati bt Abdull Patas  
Wahidah Abdul Manap

### FOREWORD BY IR DR. ILHAM BIN RUSTAM KPP FKE UITMCTKD

All praise be to Allah for the successful culmination of this collaborative endeavor between Politeknik Sultan Mizan Zainal Abidin and Universiti Teknologi MARA (UiTM) Terengganu, which has led to the publication of this compilation of Extended Abstracts. The field of Electrical Engineering continues to evolve at a remarkable pace, driven by rapid technological advancements and the increasing demand for smarter, more sustainable, and efficient systems. This publication presents a curated collection of extended abstracts derived from final year projects undertaken by students of the Electrical Engineering programs at both institutions. These projects not only reflect the students' technical capabilities but also their creativity, critical thinking, and commitment to addressing real-world engineering challenges. I would like to express my heartfelt appreciation to all contributors, particularly the editorial teams, for their dedication and hard work in bringing this publication to life. May the knowledge, methodologies, and outcomes shared within these pages serve as a source of inspiration and a foundation for future advancements in the field of Electrical Engineering. More importantly, may it continue to embody the spirit of discovery and lifelong learning that lies at the core of engineering education. Thank you.

### FOREWORD BY HAJI MOHD DASRI BIN CHE MOK @ ADNAN KJ JKE PSMZA

All praise be to Allah for the successful publication of this collection of Extended Abstracts for Final Year Projects, a collaborative effort between the Electrical Engineering Department of UiTM Terengganu and the Department of Electrical Engineering (JKE), Politeknik Sultan Mizan Zainal Abidin, Dungun, Terengganu. I extend my heartfelt congratulations to the editorial teams from both UiTM Terengganu and JKE PSMZA, as well as everyone involved in making this publication possible. This compilation showcases the work of diploma students in electrical engineering and is intended to serve as a valuable reference for students, especially those currently undertaking their final year projects. Thank you.



## **Extended Abstracts of Final Year Projects**

### **Volume 3**

#### **A SMART GLOVE SYSTEM FOR BICYCLE HAND SIGNALING ENHANCEMENT**

*CT Salwaniee binti Bahayahkhi, Zulhafiz bin Zukarmi*

**page 2**

#### **DESIGN OF IOT CLOTCHES HANGER**

*Zulkifli bin Che Din, Che Juni Luqman bin Che Hamid*

**page 5**

#### **SMART PLANT MONITORING SYSTEM**

*Hasliza Binti A Rahim @ Abd Rahman, Nurnadhirah Binti Mohd Sukri*

**page 11**

#### **TIRE PRESSURE MONITORING SYSTEM**

*Wan Azlinie binti Wan Ahmad, Danish Syakir bin Rizuan, Salmiza binti Said*

**page 14**

# A SMART GLOVE SYSTEM FOR BICYCLE HAND SIGNALING ENHANCEMENT

C T Salwaniee binti Bahayahkhi<sup>1</sup>, Zulhafiz bin Zukarmi<sup>2</sup>

<sup>1</sup>*Politeknik Sultan Mizan Zainal Abidin, Dungun, Terengganu, Malaysia*  
*salwaniee@psmza.edu.my, zulhafizz@gmail.com*

**Abstract:** Cyclist safety remains a major concern, especially in urban environments where interaction with motor vehicles is frequent. Traditional hand signals may go unnoticed by other road users, particularly in low-visibility conditions, increasing the risk of accidents. This project presents the design and implementation of a wireless bicycle brake indicator system that enables cyclists to communicate brake intentions more effectively. The system consists of a wearable glove unit equipped with a flex sensor, RF transmitter, and Arduino Pro Mini, and a rear-mounted indicator unit comprising an RF receiver and brake lights. When the cyclist clenches their fist, the flex sensor detects the motion, and a braking signal is transmitted wirelessly to activate the rear brake lights. Testing confirmed reliable performance, with consistent signal transmission and immediate light response in both indoor and outdoor environments. The system offers a lightweight, battery-powered, and user-friendly solution, demonstrating the potential of wearable technology to improve road safety and enhance cyclist visibility.

**Keywords:** flex sensor, cyclist, glove, RF transceiver.

## INTRODUCTION

Cycling, a widely embraced mode of transportation and recreation, has gained significant popularity in urban areas due to its cost-effectiveness, health benefits, and environmental sustainability. However, with the increasing number of cyclists sharing the road with motor vehicles, safety concerns have become more prominent (Schepers et al., 2015). Cyclists are considered vulnerable road users, often exposed to high risks due to limited visibility and lack of integrated signaling mechanisms. While measures such as high-visibility clothing and bike lights have been adopted to improve safety, there remains a need for more intuitive and responsive signaling tools. This project introduces an innovative solution, a signal indicator bicycle glove, is designed to enhance cyclist visibility and communication with other road users. By integrating signaling features directly into a wearable glove, the project aims to offer a practical and effective approach to reducing accidents and promoting safer cycling practices.

## METHODOLOGY

This project presents a wireless gesture-based bicycle brake system to indicate brake signals to enhance cyclist visibility and road safety. The system consists of two main components, which is a wearable glove unit, and a rear-mounted indicator unit communicate wirelessly using Radio Frequency (RF) modules. The glove unit integrates a flex sensor, RF transmitter, and Arduino Pro Mini, powered by a rechargeable battery. The flex sensor typically detects the rider's clenched fist as a braking gesture which changes the sensor's resistance. This data is processed by the Arduino and transmitted wirelessly using the RF module.

The indicator unit, mounted beneath the bicycle seat, includes an RF receiver and another unit of Arduino Pro Mini. When a brake gesture is detected and transmitted from the glove, the receiver decodes the signal and triggers both rear brake lights to illuminate. This wireless communication approach eliminates the need for physical connections between the glove and the bike, allowing for easier installation and better portability (Nevon Projects, n.d.).

This methodology combines well-established technologies in wearable sensing and embedded communication to create a lightweight, battery-powered, and user-friendly safety system for cyclists. The design is inspired by similar successful implementations of gesture-controlled systems in assistive and mobility devices (Bansode, 2020).



Figure 1: Operational block diagram for Smart Glove System for Bicycle Hand Signaling

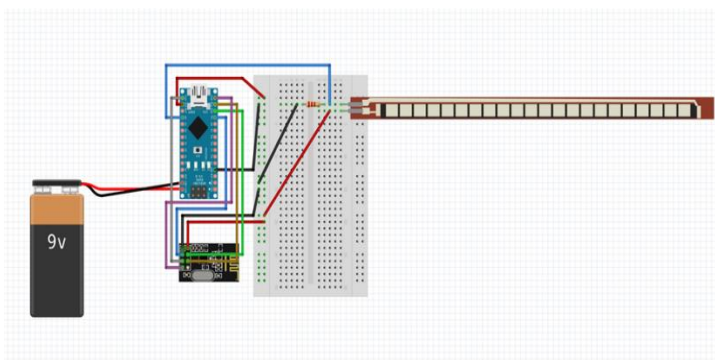

Figure 2: RF Transmitter module module

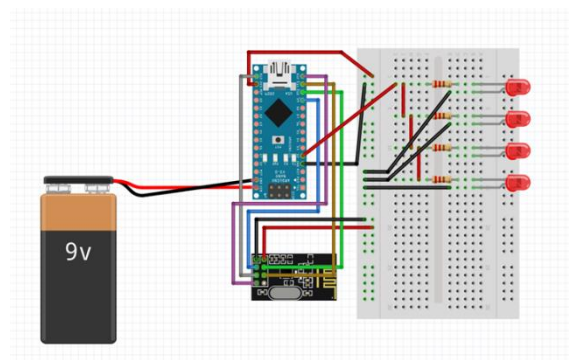

Figure 3: RF Receiver

## RESULT AND DISCUSSION

The development and implementation of the Bicycle Brake Indicator Glove system was successfully completed. The prototype functioned as intended, with the glove unit accurately detecting hand-clenching gestures through the flex sensor and transmitting braking signals to the indicator unit via RF communication. During testing, the glove demonstrated consistent performance in both indoor and outdoor environments, with the RF transmission effectively covering distances up to 10 meters in closed spaces and up to 100 meters in open areas. The rear brake lights responded promptly upon signal reception, providing clear visual alerts to surrounding road users. The wireless operation and battery-powered components enhanced user convenience, eliminating the need for external wiring. Overall, the system met all defined objectives and proved to be a practical, low-cost solution for improving cycling safety. The

results affirm the viability of gesture-controlled wearables in promoting safer road-sharing practices for cyclists.

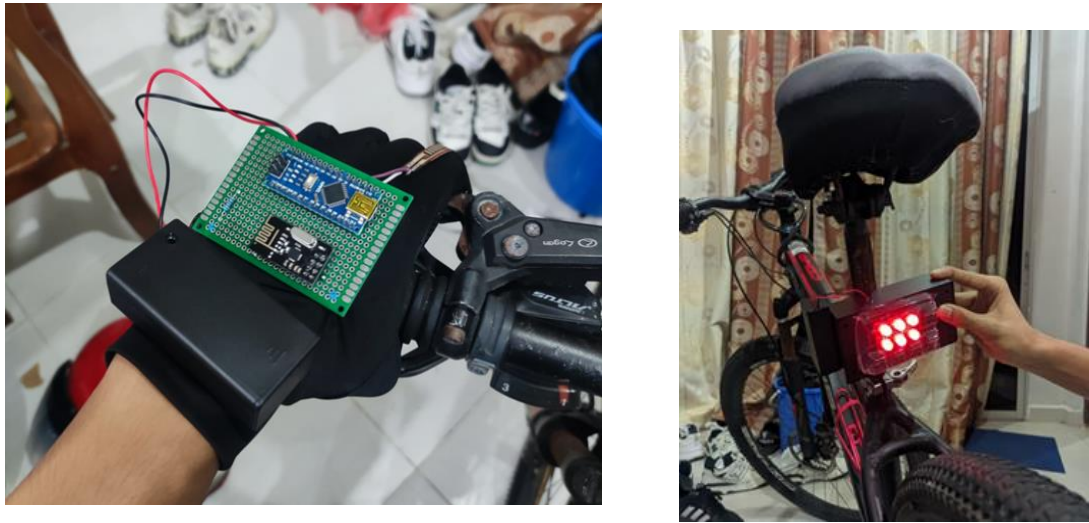

Figure 4: Result show hand clenching gesture activated signal light brake

## CONCLUSIONS

In conclusion, the development of the project system successfully addressed the core objective of enhancing cyclist safety through an intuitive, wearable signaling solution. By integrating a flex sensor-based gesture recognition mechanism with wireless RF communication, the system allows cyclists to convey braking intentions effectively without relying on traditional hand signals or wired components. The glove and indicator units demonstrated reliable performance during testing, with timely response and sufficient transmission range in both open and enclosed environments. The project not only met its design specifications but also proved to be a low-cost, lightweight, and user-friendly solution that promotes safer interactions between cyclists and other road users. This innovative approach contributes to the growing field of smart wearable technology and offers a practical application for reducing accidents and improving road safety for cyclists.

## REFERENCES

- Schepers, J. P., den Brinker, B., Methorst, R., & Helbich, M. (2015). *Pedestrian and cyclist safety performance in Dutch municipalities*. *Journal of Transport & Health*, 2(4), 329–336. <https://doi.org/10.1016/j.jth.2015.06.004>
- Nevon Projects. (n.d.). *Gesture Control Bicycle Indicator Gloves*. Retrieved from <https://nevonprojects.com/gesture-control-bicycle-indicator-gloves/>
- Bansode, A. (2020). *Flex Sensor Based Glove to Control Wheel Chair and Sign Language Translator for Speech Impaired People*. SSRN. <https://ssrn.com/abstract=3632705>.

# DESIGN OF IOT CLOTCHES HANGER

Zulkifli bin Che Din<sup>1</sup>, Che Juni Luqman bin Che Hamid<sup>2</sup>

*1,2Jabatan Kejuruteraan Elektrik, Politeknik Sultan Mizan Zainal Abidin, Dungun,  
Terengganu.*

*Zulkifli.chedin@psmza.edu.my*

**Abstract** – This project introduces a smart clothes hanger system based on the Internet of Things (IoT), designed to protect clothes from getting wet during raining day through the innovation of an automatic roof. The prototype IoT clothes hanger uses a rain sensor integrated with an ESP 32 microcontroller and motor driver to allow the roof to move automatically covers the clothesline when rain is detected. This innovative project is to purpose a prototype of an automatic hanger system to ease household chores and increase the efficiency of the hanger system. The idea for this project is to give an upgrade to the traditional cloth hanger by equipping it with sensors, a microcontroller, and motors. Therefore, this project is expected to help users make daily work at home easier and increase the efficiency of the clothes hanger. The capabilities of this hardware offer an innovative, creative and easy way to protect clothes using automation technology. IN conclusion, IoT Clothes Hanger automatic solution eliminates the human intervention, making it more practical and user-friendly.

**Keywords** - ESP32 microcontroller , rain sensor and clothes hanger

## INTRODUCTION

A clothes drying rack is a basic tool used for drying different types of clothes, such as shirts, pants, socks, headscarves, and even small carpets in traditional method of clothes drying. Although drying clothes outdoors is considered the most economical option because it does not require special equipment, this method has several disadvantages, such as being less effective when it rains suddenly and there is no supervision that can move clothes that are exposed to rain [1,2]

This project introduces uses an ESP32 microcontroller to create a smart system that can alert users through their smart devices when it suddenly starts to rain. This helps prevent the clothes from getting wet. The idea for this project came from personal experience, where clothes left on an open rack were soaked by unexpected rain. So that IoT can help manage and optimize electronic devices and electrical equipment that are already connected to the Internet [4]

Malaysia has a tropical climate, with an average yearly temperature of about 25.4 °C from 1901 to 2021. The weather often includes cloud cover in the afternoon or evening, and the country receives only around six hours of direct sunlight per day [5]. These weather conditions make it important to have an automatic system that can protect clothes when it rains. This enables proactive measures to prevent garments from becoming wet while on the drying rack. The motivation for this project stems from real-world challenges, where uncovered clotheslines are frequently exposed to sudden rain, emphasizing the need for a more efficient and practical automated solution to mitigate such occurrences.

## METHODOLOGY

This IoT **Clothes Hanger** project, a smart clothes drying system designed with an automatic roof mechanism. The system functions to protect clothes automatically when rain is detected. To ensure the success of this project, two main components were focused on: **software** and **hardware**. On the hardware side, attention was given to assembling and testing key components such as the ESP32 microcontroller, the motor driver, and the 12V DC motor used to operate the automatic roof. Refer to Figure 1 for the system's block diagram,

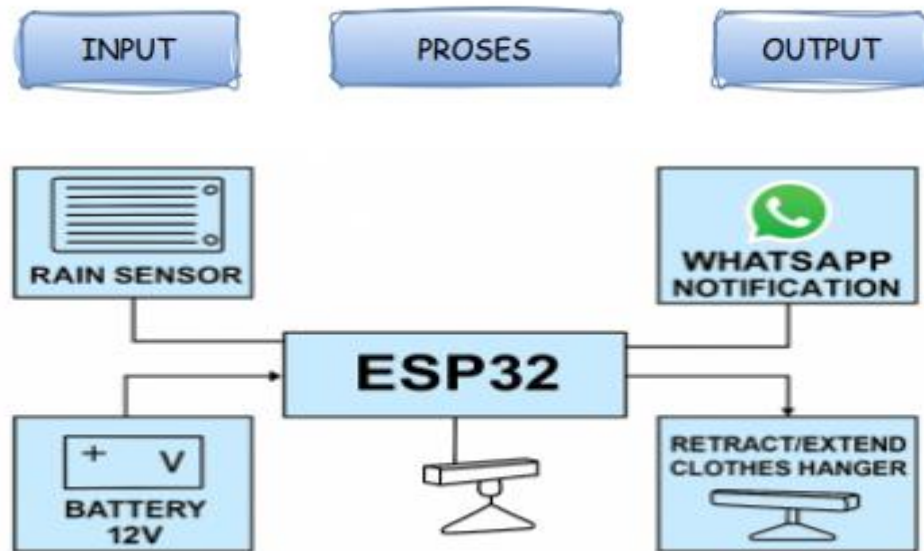

Figure 1 : Block diagram of IoT Clothes Hanger

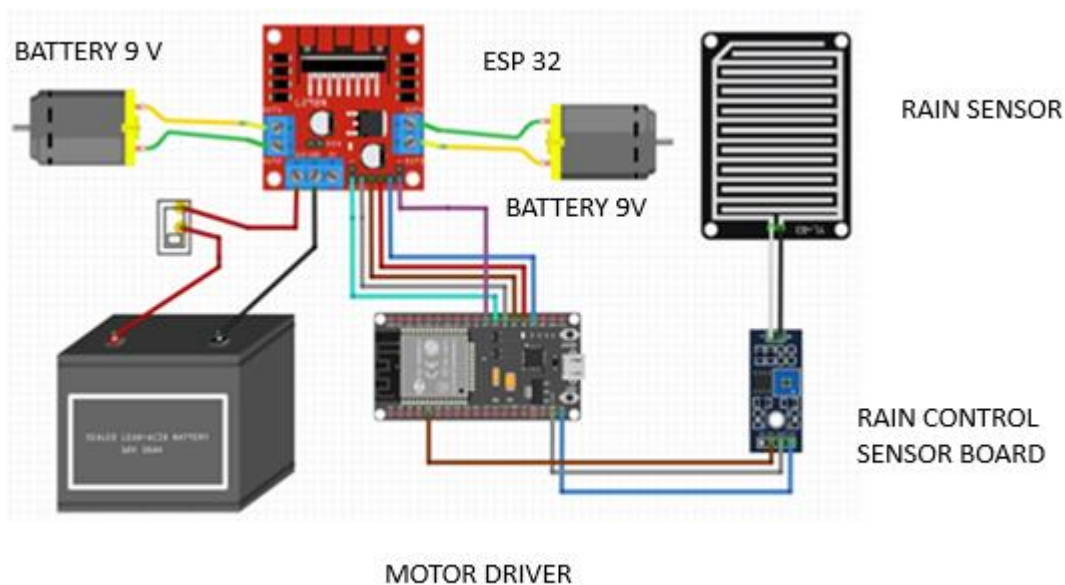

Figure 2 : Schematic diagram

The project can be divided into several main parts such as clothes hanger frame , sensor (input), Motor (output ) and controller (NodeMcu-ESP32). The clothes hanger frame will be the equipment to place load (clothes) and provide the extend/retract ability to the system. The sensors ( rain sensor) will provide input gather from the surrounding area. The motor will provide the mechanical movement for the extend and retract ability of roof. The controller will be the brain of the system. The controller will process the input and provide output based on the input of the system.

On the software side, code was developed to control the movement of the roof and to issue commands to other components. This **flowchart** illustrates the automation process of the IoT clothes hanger system equipped with an automatic roof. The system begins with a **rain sensor** detecting the presence of rain. If rain is detected, the **ESP32** receives the input from the sensor and sends a command to the **motor driver** to activate the **DC motor**, which closes the roof to protect the clothes.

Once the roof is closed, a **notification is sent to the user via WhatsApp**. When the rain stops, the sensor sends another signal to the system to reopen the roof, and a second notification is sent to the user. This process repeats every time rain is detected or stops, ensuring that the clothes are always protected automatically.

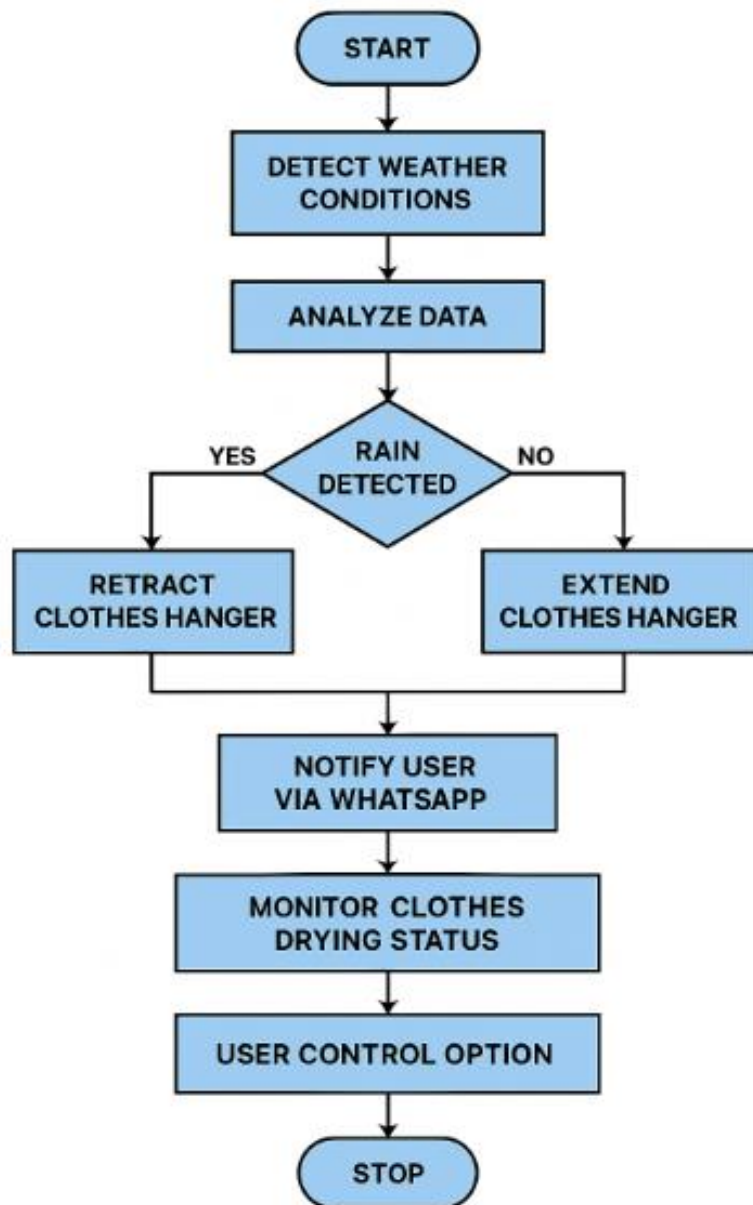

Figure 3 : Flowchart illustrates of the IoT clothes hanger system

## RESULT AND DICUSSION

The full prototype of the project had a complete circuit equipped into the frame of the system. The prototype will be run and operate in two situation which are rain and sunny. The rain situation is stimulated by using wet tissue [2] . The wet tissue will be placed on top of the rain sensor. The result of the project is displayed at Table 1

**Table 1: Result of the project**

Rain/Sunny	Hanger		Rain LED	Motor Extend LED
	Before	After		
Sunny	Retract	Extend	Off	On
Sunny	Extend	Extend	Off	On
Rain	Retract	Retract	On	Off
Rain	Extend	Retract	On	Off

## DISCUSSION

This hanger model is made from a strong **metal frame**, ensuring durability and stability in supporting the weight of hanging clothes. The metal frame underwent a **welding process** at a workshop, where two additional metal supports were added at each corner to provide **extra reinforcement** and strengthen the overall structure.



Figure 4 : Overall of the IoT clothes hanger

The IoT clothes hanger is equipped with a mechanical system designed to protect clothes from rain. The project is built using a **metal frame** with several iron rods used for hanging clothes. At the top of the hanger, there is a **fabric roof** that can be **automatically extended** to cover the clothes when rain is detected.

The system is operated by an **electronic control box** that contains an **ESP32**, a **rain sensor controller**, a **motor driver**, and **two switches**, along with **four DC motors** located at each corner to move the roof. A **12V battery** is also included as a power source for each DC motor. When the sensor detects the presence of rain, the motors are activated to extend the roof and

cover the clothes. Once the weather becomes dry again, the roof is retracted to allow the clothes to be dried under sun.

## References

- [1] Indah Purnama Sari. *Algoritma dan Pemrograman*. Medan: UMSU Press, 2023, pp. 290.
- [2] Indah Purnama Sari. *Buku Ajar Pemrograman Internet Dasar*. Medan: UMSU Press, 2022, pp. 300.
- [3] Janner Simarmata Arsan Kumala Jaya, Syarifah Fitrah Ramadhani, Niel Ananto, Abdul Karim, Betrisandi, Muhammad Ilham Alhari, Cucut Susanto, Suardinata, Indah Purnama Sari, Edson Yahuda Putra. *Komputer dan Masyarakat*. Medan: Yayasan Kita Menulis, 2024, pp.162.
- [4] World Bank Climate Change Knowledge Portal. (n.d.). <https://climateknowledgeportal.worldbank.org/country/malaysia/climate-data-historical>
- [5] Adzmi, N., Bakar, L., & Wahab, Z. A. (2022). Automatic cloth hanger system using IoT. *Progress in Engineering Application and Technology*, 3(2). <https://doi.org/10.30880/peat.2022.03.02.041>

# SMART PLANT MONITORING SYSTEM

Hasliza Binti A Rahim @ Abd Rahman<sup>1</sup>, Nurnadhirah Binti Mohd Sukri<sup>2</sup>

<sup>1,2</sup>*Department of Electrical Engineering  
Politeknik Sultan Mizan Zainal Abidin  
23000 Dungun, Terengganu  
haslizarahim@psmza.edu.my*

**Abstract:** The *Smart Plant Monitoring System* develops an automated monitoring and irrigation system for potted plants. The system is controlled by an Arduino Uno and equipped with a soil moisture sensor and a soil pH sensor. When the moisture level falls below the optimal threshold, the water pump is automatically activated. The soil pH level is also monitored, and any unsuitable readings are displayed as warnings. An 12C LCD is used to show real-time data such as moisture level, pH value, and system status. The design emphasizes ease of use, water efficiency, and improved plant care, aligning with the needs of modern, smarter, and more competitive agriculture.

**Keywords:** Automated system, Arduino Uno, soil moisture sensor, soil pH sensor, 12C LCD.

## INTRODUCTION

Smart Plant Monitoring System is an automated system specifically designed to monitor and control the basic needs of potted plants. It utilizes two main sensors, a soil moisture sensor and a pH sensor to provide a more accurate understanding of the plant's environmental conditions. The data collected by the sensors is processed by an Arduino Uno microcontroller (1) and displayed in real time on an LCD screen. This allows users to easily monitor soil moisture levels and pH values without the need for an internet connection. In addition to monitoring, the system is equipped with an automatic watering function. When the soil moisture drops below a predefined threshold, the water pump is activated automatically. If the pH reading falls outside the optimal range, the system will trigger a warning signal or carry out appropriate corrective actions. The main objective of this project is to help users care for their plants more efficiently through the use of simple, practical, and user-friendly automation technology (2). This system is particularly suitable for use at home, in schools, or in small-scale farming environments that do not require IoT-based connectivity.

## METHODOLOGY

Figure 1 shows the block diagram of Smart Plant Monitoring System. The system utilizes a soil moisture sensor and a pH sensor as input devices to measure the volumetric water content and acidity level of the soil. The sensor data is transmitted to the Arduino Uno microcontroller, which processes and evaluates the readings (3). When the soil moisture level falls below a predefined threshold (4), the Arduino triggers a water pump to initiate automatic irrigation. The real-time values of soil moisture, pH level, and irrigation status are displayed on an I2C-connected LCD module as system output. This setup allows for efficient, real-time monitoring and autonomous management of plant health conditions.

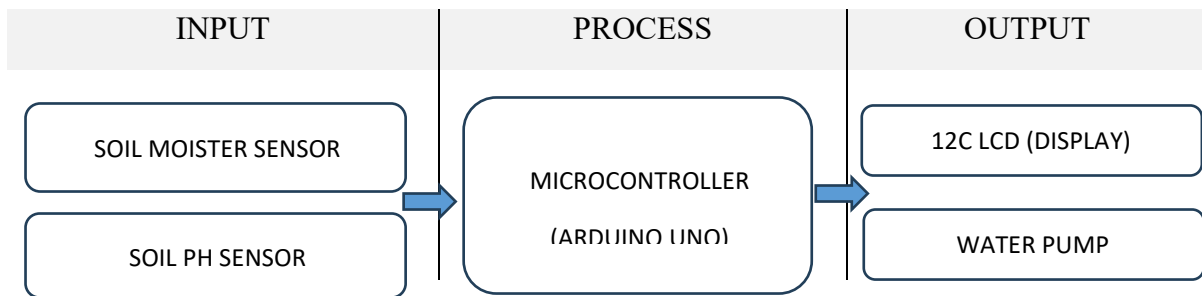

Figure 1: Block diagram of Smart Plant Monitoring System

## RESULT AND DISCUSSION

The innovation project successfully met its objectives by accurately measuring soil moisture and pH levels through sensors and processing the data via the Arduino Uno. The system effectively activated the water pump to irrigate the plant automatically whenever soil moisture dropped below the predefined threshold (5). Additionally, real-time data including moisture level, pH value, and irrigation status were clearly displayed on the I2C LCD. These outcomes demonstrate that the system can reliably monitor and manage plant health conditions with minimal manual intervention, fulfilling the project's goals.

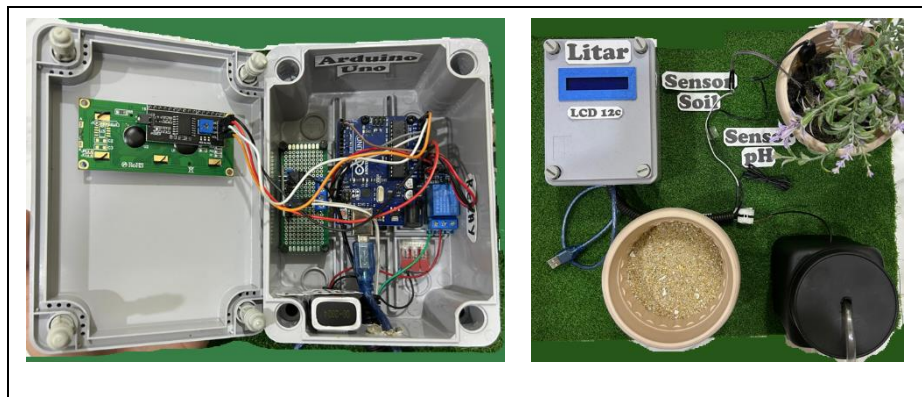

Figure 2: Smart Plant Monitoring System

## CONCLUSION

In conclusion, this project provides significant benefits to both students and lecturer by offering a practical application of embedded systems and automation in agriculture. The development process enhances students' understanding of sensor integration, microcontroller programming, and real-time data display. The system helps save time and effort in plant care by automating irrigation based on soil conditions, promoting efficient water usage and healthier plant growth (6). Overall, this project simplifies plant maintenance and serves as a valuable learning experience in the field of smart agricultural technologies.

## REFERENCES

- [1] *Introduction to Smart Agriculture with Arduino eBook*. (2023, April 24). Element14 Community. Available at: <https://community.element14.com/learn/publications/ebooks/w/documents/28124/introduction-to-smart-agriculture-with-arduino-ebook>
- [2] Adi, B., Soedarto, T., & Djazuli, R. A. (2024). *Smart farming: Solusi efisien pertanian di era teknologi*. Universitas Muhammadiyah Gresik. eprints.umg.ac.id
- [3] Budiharto, W., Suhartono, D., & Shofiyati, R. (2023). *Buku pemrograman Arduino untuk agrikultur dan smart farming*. Penerbit Buku Pendidikan Deepublish. ISBN 978-623-02-7204-2
- [4] gd-admin, & gd-admin. (2022). *What is a Soil Moisture Sensor You Should to Know*. <https://www.hengko.com/>. <https://www.hengko.com/ms/news/what-is-a-soil-sensor/>
- [5] Miae Latisha. (2025). *Sistem Pengairan Automatik Tanaman Sayuran (4)*. Scribd. <https://www.scribd.com/presentation/673046794/Sistem-Pengairan-Automatik-Tanaman-Sayuran-4>
- [6] *Introduction to Smart Agriculture with Arduino eBook*. (2023, April 24). Element14 Community. <https://community.element14.com/learn/publications/ebooks/w/documents/28124/introduction-to-smart-agriculture-with-arduino-ebook>
- [7] *pH Sensor for Soil*. (2023). Niubol.com. <https://www.niubol.com/Product-knowledge/pH-Sensor-for-Soil.html>

# TIRE PRESSURE MONITORING SYSTEM

Wan Azlinie binti Wan Ahmad, Danish Syakir bin Rizuan, Salmiza binti Said  
*Department of Electrical Engineering*  
*Politeknik Sultan Mizan Zainal Abidin*  
*23000 Dungun, Terengganu*  
*wan.azlinie@psmza.edu.my*

**Abstract:** Tire Pressure Monitoring System (TPMS) is an innovative project designed to assist road users and vehicle owners in monitoring the air pressure of their vehicle tires. Low tire pressure can cause uneven tire wear, particularly at the edges. It can also increase fuel consumption, reduce driving performance, and negatively affect vehicle handling, especially when driving on winding roads. These issues not only compromise driving comfort and efficiency but also significantly increase the risk of road accidents, particularly due to loss of control or tire failure. Therefore, it is important for vehicle owners to ensure that their tires are properly inflated to maintain the vehicle in good condition and reduce the risk of accidents. This project incorporates the Internet of Things (IoT) to improve user convenience and system efficiency, in line with current technological advancements. The system is developed using a tire pressure sensor (Pressure Transducer Sender Sensor), an Arduino Wemos D1 R2 microcontroller, a 16×2 character LCD module, and the Blynk application.

**Keywords:** TPMS, Air pressure, vehicle, safety, accident, IoT

## INTRODUCTION

Low tire pressure often causes road accidents in Malaysia, so it is important for drivers to regularly check and maintain proper tire pressure. The Tire Pressure Monitoring System (TPMS) was developed to help road users easily monitor tire pressure and stay aware of their tire condition, ensuring their vehicles remain safe to drive. This product was created to address common issues related to tire maintenance. Underinflated tires can make a vehicle harder to control and increase braking distance, leading to a higher risk of accidents. Many drivers are unaware that their tire pressure is low until it becomes dangerous. Incorrect tire pressure also leads to higher fuel consumption and carbon emissions, which negatively affect the environment and increase fuel costs. Additionally, improper tire pressure can cause uneven tire wear, shorten tire lifespan, and raise maintenance expenses. Since not all vehicle owners have tire pressure checking tools at home, they often need to visit petrol stations just to perform a simple check. This project focuses on developing a device that can accurately read and display tire air pressure. Its goal is to reduce road accidents caused by tire-related issues while also promoting sustainability by minimizing unnecessary tire waste and material usage. The TPMS is designed using the Arduino Wemos D1 R2 microcontroller, an air pressure transducer sensor as the input, and a 16x2 Liquid Crystal Display (LCD) to show tire pressure readings. The system also sends real-time notifications to users via the Blynk application, making it convenient and user-friendly. The TPMS alerts drivers when tire pressure is too low or abnormal. It is cost-effective and offers a reliable solution for regular tire monitoring. This product supports ongoing efforts in the automotive industry to enhance safety, efficiency, and environmental sustainability. The idea for this TPMS was inspired by existing systems, but it

offers a more affordable and accessible solution with added IoT features. The system has been successfully developed and has met all its intended objectives, providing both safety and convenience for vehicle users.

## METHODOLOGY

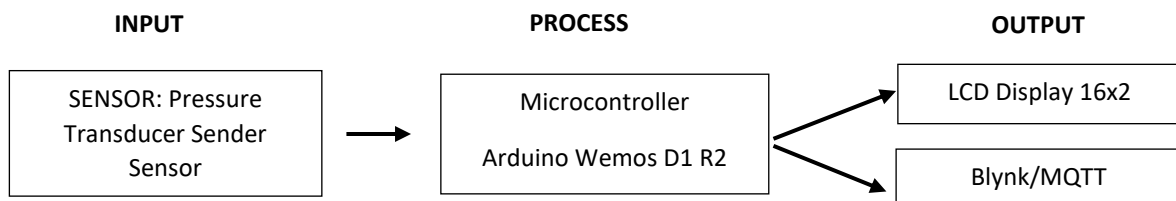

Figure 1: Block Diagram of Tire Pressure Monitoring System

Figure 1 shows the block diagram of the project. The system starts when the pressure transducer sender sensor detects the air pressure inside the tire. This pressure data is then sent to the microcontroller, which is the Arduino Wemos D1 R2. The microcontroller processes the pressure readings and sends the results to both the 16x2 LCD Display and the Blynk or MQTT mobile application for monitoring. The LCD displays real-time pressure status, while the Blynk/MQTT interface allows remote monitoring through a mobile gadget.

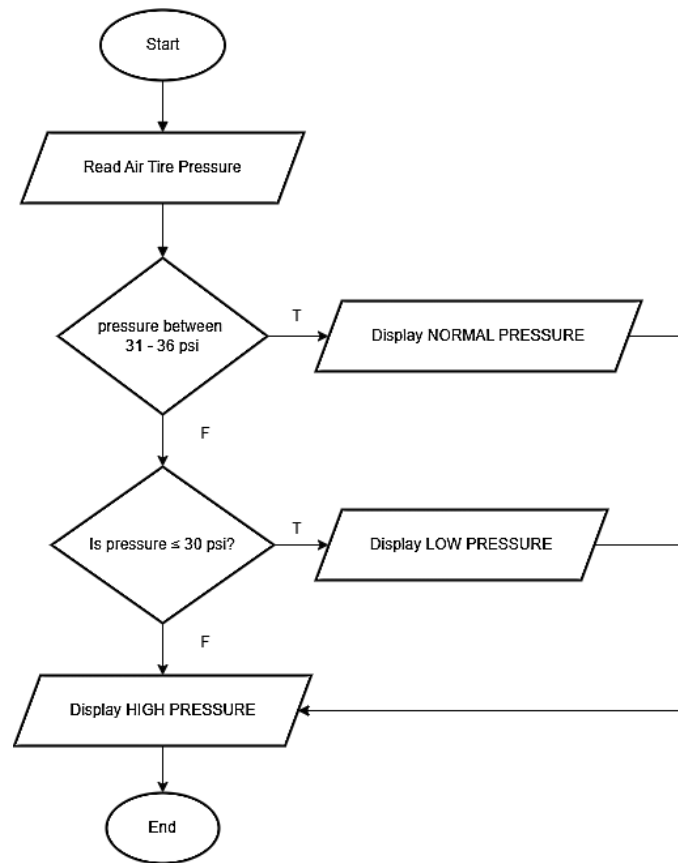

Figure 2: Flow Chart of Tire Pressure Monitoring System

This flowchart shows how the system checks tire pressure and displays a message based on the reading. The system displays 'NORMAL PRESSURE' when the pressure is between 31 and 36 psi. If the pressure falls below 31 psi, it displays 'LOW PRESSURE', whereas a reading above 36 psi prompts the display of 'HIGH PRESSURE'. This helps users monitor tire conditions easily.



Figure 3: Prototype of Tire Pressure Monitoring System

## RESULT AND DISCUSSION

The Tire Pressure Monitoring System has successfully achieved its objective by accurately categorizing tire pressure levels based on specific pressure ranges. The system displays 'NORMAL PRESSURE' when the pressure ranges between 31 and 36 psi. When the pressure drops below 31 psi, it shows 'LOW PRESSURE', while a pressure reading above 36 psi triggers the display of 'HIGH PRESSURE'. This clear and real-time indication allows users to easily monitor tire conditions.

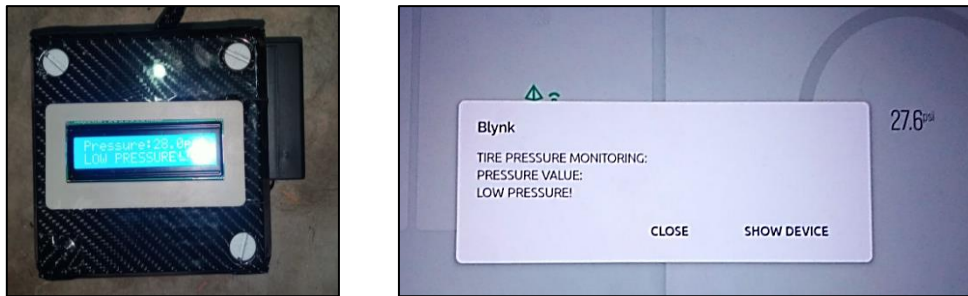

Figure 4: Example of a reading from the Tire Pressure Monitoring System

## CONCLUSION

The Tire Pressure Monitoring System was developed to enhance road safety by providing real-time tire pressure data, thereby helping to reduce accidents caused by underinflated or overinflated tires. By integrating IoT technology, the system aligns well with modern digital lifestyles and offers strong potential for commercialization, particularly within the Malaysian automotive market. For future development, the system can be improved by using a more compact microcontroller such as the NodeMCU ESP8266 and by optimizing power consumption. These improvements would make the system more compact, portable, and environmentally friendly.

## REFERENCES

- Koringa, A. (2023, Dec 19). The Evolution of Smart Tire Pressure Monitoring Systems (TPMS). <https://medium.com/@akashkoringa/the-evolution-of-smart-tire-pressure-monitoring-systems-tpms-e95e6c05188b>
- Tires. (n.d.). National Highway Traffic Safety Administration. <https://www.nhtsa.gov/vehicle-safety/tires>