

# ELECTRICAL ENGINEERING INNOVATION COMPETITION & EXHIBITION 2025



## LIST OF EDITORS:

### FKE

Mazratul Firdaus Mohd Zin  
Suziyani Rohafauzi  
Dayana Kamaruzaman  
Mohamad Taib Miskon  
Nur Idawati MdENZai

### JKE

Norfadhilah Hasan  
Nor Hasnati bt Abdull Patas  
Wahidah Abdul Manap

### FOREWORD BY IR DR. ILHAM BIN RUSTAM KPP FKE UITMCTKD

All praise be to Allah for the successful culmination of this collaborative endeavor between Politeknik Sultan Mizan Zainal Abidin and Universiti Teknologi MARA (UiTM) Terengganu, which has led to the publication of this compilation of Extended Abstracts. The field of Electrical Engineering continues to evolve at a remarkable pace, driven by rapid technological advancements and the increasing demand for smarter, more sustainable, and efficient systems. This publication presents a curated collection of extended abstracts derived from final year projects undertaken by students of the Electrical Engineering programs at both institutions. These projects not only reflect the students' technical capabilities but also their creativity, critical thinking, and commitment to addressing real-world engineering challenges. I would like to express my heartfelt appreciation to all contributors, particularly the editorial teams, for their dedication and hard work in bringing this publication to life. May the knowledge, methodologies, and outcomes shared within these pages serve as a source of inspiration and a foundation for future advancements in the field of Electrical Engineering. More importantly, may it continue to embody the spirit of discovery and lifelong learning that lies at the core of engineering education. Thank you.

### FOREWORD BY HAJI MOHD DASRI BIN CHE MOK @ ADNAN

All praise be to Allah for the successful publication of this collection of Extended Abstracts for Final Year Projects, a collaborative effort between the Electrical Engineering Department of UiTM Terengganu and the Department of Electrical Engineering (JKE), Politeknik Sultan Mizan Zainal Abidin, Dungun, Terengganu. I extend my heartfelt congratulations to the editorial teams from both UiTM Terengganu and JKE PSMZA, as well as everyone involved in making this publication possible. This compilation showcases the work of diploma students in electrical engineering and is intended to serve as a valuable reference for students, especially those currently undertaking their final year projects. Thank you.

EEICE 2025 | Volume 2  
e-ISSN 2682-7565  
Online July 2025

BARCODE:

eISSN 2682-7565



9 772682 756001



# ELECTRICAL ENGINEERING INNOVATION COMPETITION & EXHIBITION 2025



ORGANIZED BY  
FAKULTI KEJURUTERAAN ELEKTRIK  
UiTM CAWANGAN TERENGGANU KAMPUS DUNGU  
(UITMCTKD)



IN COLLABORATION  
JABATAN KEJURUTERAAN ELEKTRIK  
POLITEKNIK SULTAN MIZAN ZAINAL ABIDIN  
(PSMZA)



## Extended Abstracts of Final Year Projects

### Volume 2

<b>SOLAR POWERED SOIL MOISTURE SENSOR WITH THE LCD</b> <i>Muhammad Arif Zakwan Mohd Azam, Norizan Ahmed, Baktiar Musa</i>	<b>page 2</b>
<b>SOLAR POWERED AUTOMATIC ROOF COOLING SYSTEM</b> <i>Muhammad Syaffiq Aiman Sulaiman, Wan Ahmad Khusairi Wan Chek, Hasrul Hafiz Abu Bakar, Ahmad Izzat Mod Arifin, Fadhli Dzul Hilmi Mohd Fauzi</i>	<b>page 5</b>
<b>SOLAR POWERED AUTOMATIC COLLISION AVOIDANCE TOY CAR</b> <i>Raja Muhammad Amierul Raja Mamat, Siti Aishah binti Che Kar, Syazilawati Mohamed</i>	<b>page 8</b>
<b>SMART SOLAR POWERED CROP PROTECTION AND IRRIGATION SYSTEM WITH IOT</b> <i>Faris Aizzat Pauzi, Nurbaiti Wahid</i>	<b>page 11</b>
<b>POWERED SOLAR WATER IRRIGATION FOR CHILLI PLANTATION</b> <i>Muhammad Abdul Hayei Abdul Razak, Siti Aishah binti Che Kar</i>	<b>page 14</b>

# SOLAR POWERED SOIL MOISTURE SENSOR WITH THE LCD

Muhammad Arif Zakwan Mohd Azam, Norizan Ahmed, Baktiar Musa  
*Faculty of Electrical Engineering,  
Universiti Teknologi MARA Cawangan Terengganu,  
Kampus Dungun, 23000 Dungun, Terengganu, Malaysia*  
[baktiar@uitm.edu.my](mailto:baktiar@uitm.edu.my)

**Abstract:** The project develops a solar-powered soil moisture monitoring system using components like a soil moisture sensor, solar panel, rechargeable battery, Arduino Uno, LCD display, and buzzer to measure soil moisture levels in real-time and provide both visual and auditory feedback for efficient and sustainable soil condition monitoring. The soil moisture sensor detects moisture content through electrical resistance, with the Arduino Uno processing this data to display moisture levels on the LCD screen. When the moisture level falls below or exceeds a predefined threshold, the buzzer is activated to alert the user, ensuring timely intervention. Powered by a solar panel and rechargeable battery, the system is energy-efficient and environmentally friendly. The LCD display offers a user-friendly interface, while the buzzer acts as an auditory warning for critical moisture levels, creating an autonomous and sustainable solution for agriculture or gardening. This project provides hands-on experience in renewable energy, sensor integration, and microcontroller programming, demonstrating an innovative and eco-friendly approach to soil moisture monitoring.

**Keywords:** Solar-powered, Arduino Uno, soil moisture sensor, renewable energy, agriculture

## INTRODUCTION

The project focused on developing a solar-powered soil moisture monitoring system capable of detecting soil dryness and alerting users through a buzzer and an LCD display. The system incorporated a soil moisture sensor to measure soil moisture levels and an Arduino Uno to process the sensor data. When the soil moisture dropped below a predefined threshold, the Arduino activated the buzzer to alert the user and displayed the current moisture level on the LCD screen. A solar panel provided power to the system, ensuring sustainable and continuous monitoring without the need for an external power source. Soil moisture monitoring systems use sensors to assess moisture levels and provide timely feedback to users. This highlights the importance of integrating soil moisture sensors for efficient water management in agricultural and gardening applications. Soil moisture monitoring is an essential feature in precision agriculture, as it allows for optimized irrigation and better water resource management without constant human oversight.

A solar-powered soil moisture monitoring system using Arduino can effectively detect soil dryness and provide necessary alerts. This project demonstrated how embedded technology, and sensors could enhance the functionality of agricultural systems, making them smarter and more resource efficient. By integrating real-time soil moisture detection, the system enabled users to respond promptly to changing soil conditions, reducing water wastage and promoting healthier plant growth. Additionally, the implementation of a buzzer and an LCD display ensured clear and immediate communication of soil conditions to the user. Feedback mechanisms like buzzers and displays are necessary components for effective monitoring and response in agricultural applications.

## METHODOLOGY

Figure 1 illustrates the system and operation diagram of the project. The connections for the soil moisture monitoring system are as follows: The DHT sensor is connected to the Arduino with its VCC pin linked to the 5V pin, GND to GND, and DATA to pin 2. The LCD display (16x2 with I2C module) has its VCC connected to 5V, GND to GND, SDA to A4, and SCL to A5 on the Arduino. The buzzer is connected with its positive terminal to pin 9 and its negative terminal to GND. This setup allows the

Arduino to read moisture levels from the DHT sensor, display the readings on the LCD, and activate the buzzer when the moisture level drops below the threshold.

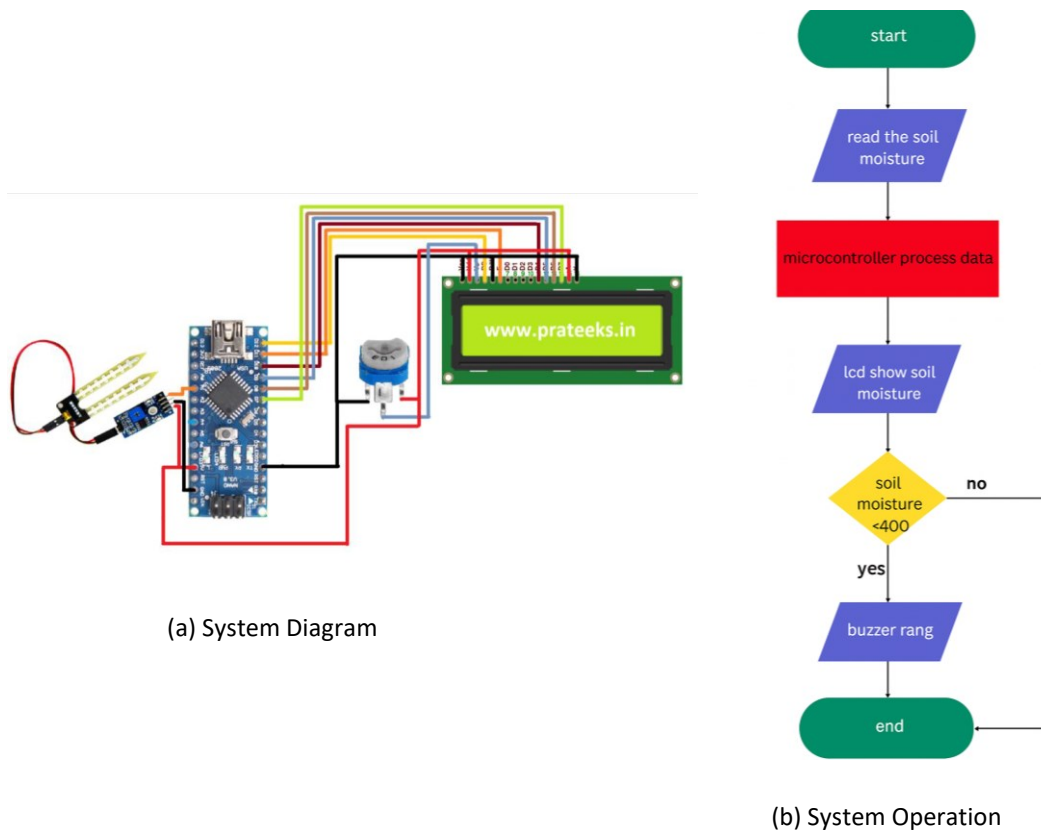
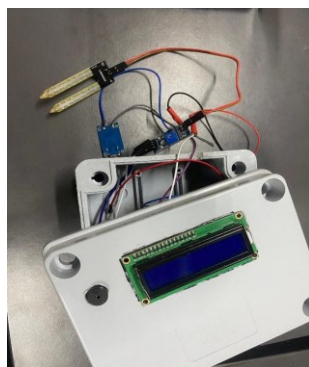
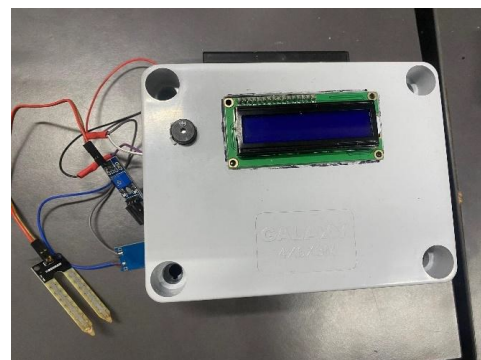

Figure 1. (a) System diagram and (b) operation of the project

As shown in Figure 2 below, the solar-powered soil moisture monitoring system involves assembling key components, including the Arduino Uno, DHT sensor, LCD display, buzzer, and a solar power source. These components are securely connected with the DHT sensor placed in the soil to measure moisture levels. Arduino acts as the main controller, processing input from the DHT sensor and displaying real-time moisture readings on the LCD. If the moisture level drops below a set threshold, the Arduino activates the buzzer to alert the user. Power is supplied through a solar panel, ensuring energy-efficient operation. Once assembled, the system is tested to verify its functionality, allowing for accurate soil moisture monitoring and timely alerts for efficient irrigation.



(a) Hardware Connection



(b) Completed prototype

Figure 2. The hardware connection and the completed prototype with PCB and battery dan PCB inside the box

## RESULT AND DISCUSSION

Figure 3 shows the simulation results of the project as well as the completed device. At the outset of the project, the DHT sensor begins monitoring the soil's moisture level, continuously measuring and sending real-time data to the Arduino microcontroller. The Arduino processes this data and displays the moisture level on the LCD screen. If the moisture level falls below a predefined threshold, the Arduino promptly activates the buzzer, alerting the user that watering is needed. The system then continues its monitoring cycle, with the DHT sensor repeatedly assessing the soil's condition. Each time the moisture level drops below the threshold, the alert sequence is triggered, ensuring timely intervention for plant health. This continuous process of sensing, processing, and alerting exemplifies the efficient integration of sensor feedback and automated response mechanisms, making irrigation management more reliable and effective.

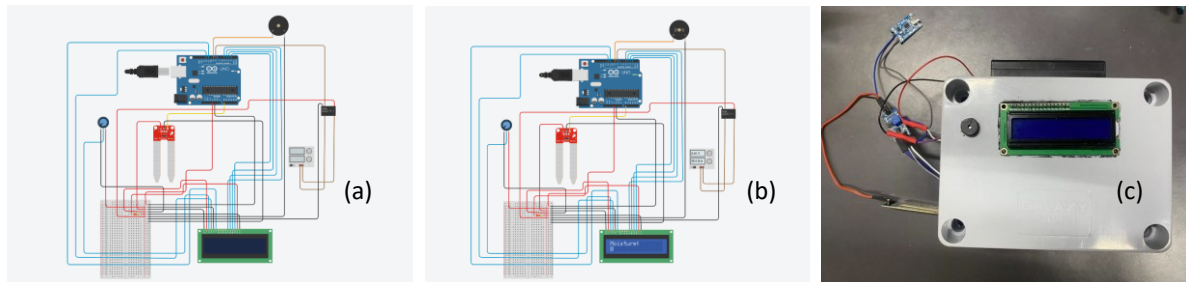

**Figure 3. (a) Connection of the circuit on the breadboard (b) Simulation test when ultrasonic sensor sense obstacle (c) Completed device**

## CONCLUSION

In conclusion, this project exemplifies the successful integration of sensor technology and automated control mechanisms to enhance the efficiency and reliability of soil moisture monitoring. By leveraging components such as the DHT sensor, LCD display, buzzer, and Arduino Uno, the system provides real-time moisture level readings and alerts users when irrigation is needed. The continuous monitoring process ensures timely intervention, promoting healthier plant growth and more efficient water management. Additionally, the incorporation of a solar power source highlights a commitment to sustainability, reducing reliance on conventional energy and making the system more eco-friendly. Through meticulous design, structured wiring using a PCB, and thorough testing, this project offers valuable insights for further improvements and broader applications in agricultural automation. Ultimately, this system demonstrates the potential of integrating smart technologies to create practical, energy-efficient solutions that contribute to sustainable farming and resource conservation.

## REFERENCES

- [1] G. Civeira, 'Introductory Chapter: Soil Moisture', Soil Moisture. IntechOpen, Feb. 27, 2019. doi: 10.5772/intechopen.83603
- [2] Xiaomo Zhang, Gary Feng, Xin Sun, 'Advanced technologies of soil moisture monitoring in precision agriculture: A Review', Journal of Agriculture and Food Research, Volume 18, 2024, 101473
- [3] A. P. Nugroho *et al.*, "Development of Soil Moisture Content Monitoring System for Precision Measurement of Soil Moisture in Sub-Optimal Land for Palm Oil Plantation," in *BIO Web of Conferences*, EDP Sciences, Oct. 2023. doi:10.1051/bioconf/20236905003.
- [4] Sarkar S & Dixon H (eds) 2021. Emerging Science for Sustainable Water Resource Management: A Guide for Water Professionals and Practitioners in India. UKCEH Wallingford 94pp.

# SOLAR POWERED AUTOMATIC ROOF COOLING SYSTEM

Muhammad Syaffiq Aiman Sulaiman, Wan Ahmad Khusairi Wan Chek, Hasrul Hafiz Abu Bakar, Ahmad Izzat Mod Arifin, Fadhli Dzul Hilmi Mohd Fauzi  
*Faculty of Electrical Engineering,  
Universiti Teknologi MARA, Cawangan Terengganu  
Kampus Dungun, 23000 Dungun, Terengganu, Malaysia.*  
[khusairi5079@uitm.edu.my](mailto:khusairi5079@uitm.edu.my)

**Abstract:** During Malaysia's annual drought season, temperatures soar to 36–39°C, causing intense heat, especially on roadside stalls and restaurant roofs. To address this, a solar-powered roof cooling system controlled by an Arduino is proposed. Solar panels supply power to the system, connected to a charge controller and battery for energy storage. The cooling setup includes a roof-mounted water sprinkler and an exhaust fan. Since solar panels produce DC power, a DC-to-AC converter is used to run the AC exhaust fan. Traditional air conditioning is too costly and energy-intensive for small roadside businesses and open-air restaurants. This alternative cooling solution offers a more affordable and sustainable way to reduce heat, making these businesses more comfortable during hot periods while lowering energy consumption and costs. The system aims to improve comfort and sustainability without relying on expensive conventional air conditioning.

**Keywords:** Solar-powered roof cooling, Arduino control, roof sprinkler system.

## INTRODUCTION

In the context of increasing global temperatures and urban heat island effects, innovative strategies are required to enhance building energy efficiency and occupant comfort. Rooftop surfaces, being directly exposed to solar radiation, are significant contributors to indoor heat gain.

Many related works have been proposed such as in [1] that rainwater harvesting, solar-powered fans, and sensor-based controls were integrated to cool attic spaces. Airflow and water distribution were managed automatically. The effectiveness of combining passive and active cooling in reducing indoor temperatures and energy consumption in tropical climates was demonstrated. Another project [2] that studies that compares performance of a PV panel without cooling to one equipped with a hybrid air-and-water cooling system. The system uses a DC water pump and fan, activated automatically when the panel temperature exceeds a set threshold, to reduce heat and improve power output. This approach demonstrates that regulating panel temperature can effectively enhance energy efficiency.

This project aims to develop a solar-powered rooftop cooling system for roadside stalls and open-air restaurants, where air conditioning is often too expensive. The system uses solar panels to generate electricity, which is stored in batteries. Cooling is provided by a rooftop water sprinkler and an exhaust fan, powered through a DC-to-AC converter. This setup offers a cost-effective and energy-efficient alternative to traditional cooling methods, helping improve comfort in outdoor commercial spaces.

## METHODOLOGY

This section explains the operation of the project using the block diagram shown in Figure 1. Figure 1 illustrates the overall system diagram for the project, where the primary power generation source is the solar panel. The solar panel produces direct current (DC) output and is connected to a solar charge controller. The main function of the solar charge controller is to ensure the safe and efficient operation of solar energy systems by regulating battery charging, preventing damage from overcharging or discharging, and providing various protective features [3]. The solar charge controller then charges the battery. Since the load apparatus used in this project operates on alternating current (AC), a DC to AC

inverter is necessary to convert the DC supply into AC supply to meet the load requirements. The DHT22 temperature sensor is connected to an Arduino Mega to monitor the temperature and the humidity. When the DHT22 detects that the ambient temperature exceeds a set threshold, the Arduino Mega automatically activates a water pump to spray the roof and an exhaust fan to ventilate the room. For enhanced safety, this project incorporates a miniature circuit breaker (MCB) on its AC circuit.

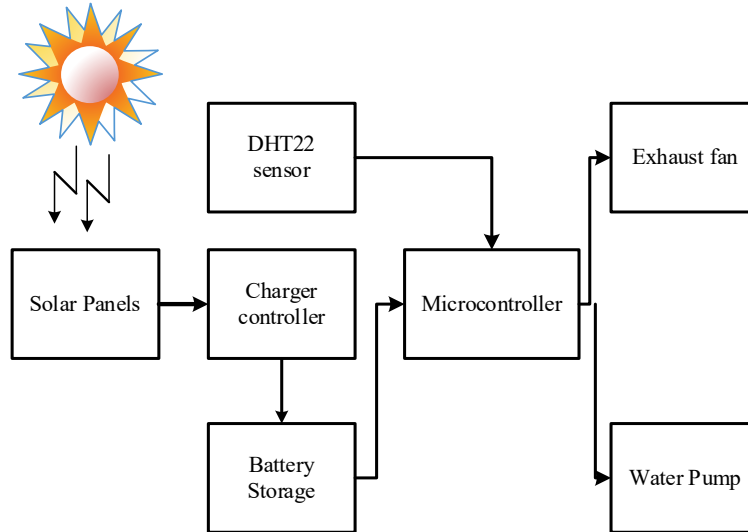

Figure 1. Block diagram of Solar Powered Automatic Roof Cooling System

## RESULT AND DISCUSSION

Table 1 below presents the control logic of a temperature-based system that is monitored using a DHT22 sensor. When the temperature rises above 30°C, the exhaust fan and water pump are activated to cool the area. If the temperature is 30°C or lower, both devices are deactivated to conserve energy.

Table 1. DHT22 sensor testing

Output	Condition	Action
Water Pump	Temperature > 30°C	Turn ON
Water Pump	Temperature ≤ 30°C	Turn OFF
Exhaust Fan	Temperature > 30°C	Turn ON
Exhaust Fan	Temperature ≤ 30°C	Turn OFF

Figure 2 illustrates the operational behavior of the fan and water pump based on DHT22 sensor readings. As mentioned in Table 1, both outputs are activated when the sensor detects a temperature below 30°C.



Figure 2. Water pump and exhaust fan testing

## CONCLUSION

The automated cooling system, which employs a DHT22 sensor and utilizes solar energy to power a water pump and exhaust fan, has effectively reduced electricity costs for roadside stalls and open-air restaurants. To further improve its performance, upgrading to a high-pressure water pump is recommended for enhanced water delivery. Additionally, integrating IoT technology for remote operation could optimize system efficiency, making it a more reliable solution for maintaining comfortable conditions in outdoor dining settings.

## REFERENCES

- [1] M. C. Yew, S. W. Wong, M. K. Yew, and L. H. Saw, "Rainwater Harvesting System Integrated With Sensors for Attic Temperature Reduction," *Front Built Environ*, vol. 7, Apr. 2021, doi: 10.3389/fbuil.2021.647594.
- [2] M. Akther *et al.*, "Design and Implementation of a PV Hybrid Air-Water Cooling System," in *7th International Conference on Development in Renewable Energy Technology, ICDRET 2024*, Institute of Electrical and Electronics Engineers Inc., 2024. doi: 10.1109/ICDRET60388.2024.10504064.
- [3] "Solar Charge Controller Basics | NAZ Solar Electric." Accessed: May 29, 2025. [Online]. Available: <https://www.solar-electric.com/learning-center/batteries-and-charging/solar-charge-controller-basics.html/>

# SOLAR POWERED AUTOMATIC COLLISION AVOIDANCE TOY CAR

Raja Muhammad Amierul Raja Mamat, Siti Aishah binti Che Kar, Syazilawati Mohamed

*Faculty of Electrical Engineering,*

*Universiti Teknologi MARA Cawangan Terengganu*

*Kampus Dungun, 23000 Dungun, Terengganu, Malaysia.*

[sitia2500@uitm.edu.my](mailto:sitia2500@uitm.edu.my)

**Abstract:** The project focuses on developing an obstacle avoidance toy car using components such as motor driver, ultrasonic sensor, servo motor, Arduino Uno, DC motors, and battery. This system is designed to enable real-time obstacle detection and avoidance, ensuring smooth and autonomous navigation. The ultrasonic sensor detects obstacles by emitting ultrasonic waves and measuring the time it takes for them to return after hitting an object. The Arduino Uno processes this data to calculate the distance to the obstacle. Based on this input, it sends commands to the L298N motor driver, which controls the DC motors to stop, reverse, or turn the car. The servo motor rotates the ultrasonic sensor, allowing it to scan the surroundings for obstacles, providing a wider detection range. The L298N motor driver efficiently manages the car's movements, while the battery powers the system. Together, these components create a self-operating vehicle capable of navigating safely and avoiding collisions. This project offers a practical and engaging way to explore robotics, motor control, and sensor integration. It fosters hands-on learning while showcasing an innovative and reliable solution for creating autonomous toy vehicles.

**Keywords:** Collision avoidance, Ultrasonic Sensor, Arduino, Solar Powered

## INTRODUCTION

The project focused on creating an obstacle-avoiding toy car that can move safely and avoid collisions. The system used an ultrasonic sensor to detect obstacles, a servo motor to rotate the sensor for better coverage, and an Arduino Uno to process the data. When an obstacle was detected, the Arduino sent commands to the L298N motor driver to stop, turn, or change the car's direction. A battery powered the car, and all parts worked together to allow it to navigate on its own. This system showed how technology could make toy cars smarter and more interactive. By using sensors and simple automation, the car could move without needing human control to avoid obstacles. The project was designed to be an easy and fun way for students and hobbyists to learn about robotics and programming. It gave them hands-on experience with motors, sensors, and controllers. As interest in smart and autonomous systems grows, this obstacle-avoiding toy car provided a simple but effective introduction to the world of robotics and self-driving technology.

## METHODOLOGY

The block diagram represents the working mechanism of a Solar-Powered Automatic Collision Avoidance Toy Car. At the core of the system is the Ultrasonic Distance Sensor, which detects obstacles in the path of the toy car by measuring the distance to nearby objects. This sensor sends the data to the Arduino Uno, which acts as the brain of the system. Integrated with an H-Bridge Motor Driver, the Arduino interprets the distance data and controls the motion of the car accordingly. If an obstacle is detected within a predefined range, the Arduino sends commands to the Servo Motor to steer the wheels and to the Gear Motor to adjust the speed or direction of the car, thereby avoiding collisions. The entire system is powered by solar energy, promoting eco-friendly operation while enabling autonomous navigation without manual control. This design ensures safe and intelligent movement of the toy car by integrating sensor feedback with real-time motor control.



Figure 1. Block diagram of the project

## RESULT AND DISCUSSION

The flowchart shown in Figure 2 outlines the decision-making process for an obstacle-avoidance toy car. The system begins with the car measuring the distance to objects in three directions: center, left (at 45 degrees), and right (at 90 degrees) using the ultrasonic sensor. If an obstacle is detected at a distance of less than 20 cm, the car stops its motors to avoid a collision. At this point, the system compares the distances measured on the left and right sides to determine the best direction to turn. If the distance on the left side is greater than the distance on the right, the car turns left to navigate around the obstacle. Otherwise, the car turns right if the right side offers more space. Once the car has successfully turned in a safe direction, the process restarts by measuring distances again. However, if no obstacle is detected (i.e., all distances are greater than 20 cm), the car continues moving forward without interruption. This flowchart ensures the toy car can autonomously navigate its environment by continuously evaluating distances and making decisions to avoid obstacles while maintaining smooth movement.

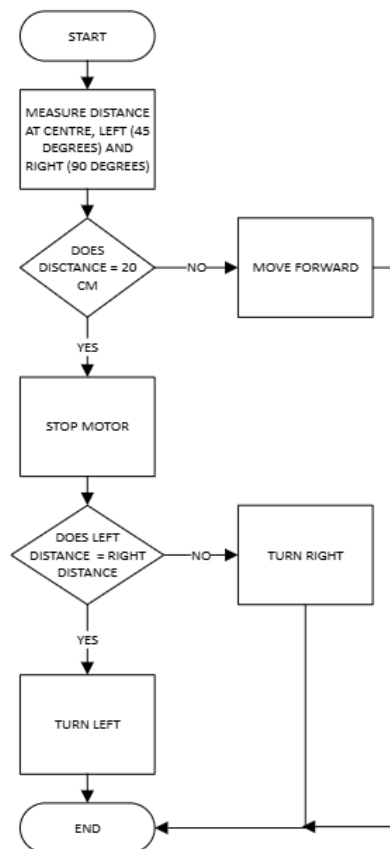

Figure 2. Flow chart diagram of the project

## CONCLUSION

In conclusion, this project exemplifies the successful integration of advanced sensor technology and precise control mechanisms to enhance the functionality, safety, and durability of toy prototypes. By leveraging components such as servo motors, ultrasonic sensors, gear motors, and Arduino

microcontrollers, the project achieves autonomous obstacle detection and navigation capabilities. The systematic approach of scanning, halting, maneuvering, and resuming forward motion in response to obstacle detection demonstrates the toy's ability to navigate complex environments with agility and reliability. Moreover, the incorporation of renewable energy sources like solar panels underscores a commitment to sustainable practices in consumer electronics.

## REFERENCES

- [1] T. Dehraj, S. A. Memon, and A. A. Memon, "Obstacle Avoiding Robot," *Journal of Applied Engineering and Technology*, vol. 3, no. 1, pp. 37–43, 2019.
- [2] M. A. Baballe and M. I. Bello, "Obstacle Avoidance Robot using an Ultrasonic Sensor with Arduino," *East African Scholars Journal of Engineering and Computer Sciences*, vol. 6, no. 6, pp. 78–86, 2023.
- [3] T. Mahmud, I. Ara, and R. Chakma, "Design and Implementation of an Ultrasonic Sensor-Based Obstacle Avoidance System for Arduino Robots," in *Proceedings of the 2023 International Conference on Information and Communication Technology for Sustainable Development (ICICT4SD)*, 2023, pp. 1–6.
- [4] Y. Koren, "Obstacle Avoidance with Ultrasonic Sensors," *IEEE Journal on Robotics and Automation*, vol. 2, no. 3, pp. 138–146, 1986.
- [5] S. A. Zulkifli, K. B. Ching, M. Z. Ahmad, R. Hamdan, and N. A. Ibrahim, "Study of Poles and Zeros Arrangement Method for PID Controller on TCSC," in *Proceedings of the 13th International Conference on Harmonics and Quality of Power (ICHQP)*, 2008, pp. 1–6.

# SMART SOLAR POWERED CROP PROTECTION AND IRRIGATION SYSTEM WITH IoT

Faris Aizzat Pauzi, Nurbaiti Wahid  
Faculty of Electrical Engineering,  
Universiti Teknologi MARA Cawangan Terengganu,  
Kampus Dungun, 23000, Dungun Terengganu, Malaysia.  
[nurbaiti@uitm.edu.my](mailto:nurbaiti@uitm.edu.my)

**Abstract:** This project proposes the development of an Enhanced Smart Solar-Powered Crop Protection and Irrigation System with IoT to address challenges in modern agriculture, including wild animal intrusion, water scarcity, and limited access to advanced technologies. Farmers often suffer from crop losses due to wildlife, inefficient water use, and lack of resources to adopt smart farming solutions. The proposed system integrates real-time monitoring, image analysis, and automation to tackle these issues effectively. A camera module enables early detection of wild animals, while soil moisture and passive infrared (PIR) sensors are used to send the measured signals to the microcontroller to optimize irrigation and strengthen crop protection. The system operates autonomously by using solar power and incorporates a water pump and buzzer for immediate responses. A user-friendly mobile interface supports remote monitoring and control, empowering farmers to manage their system efficiently. By promoting water conservation, early detection, and scalable implementation, this solution enhances agricultural sustainability and productivity, particularly in remote or resource-constrained areas.

**Keywords:** Crop protection, irrigation, IOT, soil moisture, PIR.

## INTRODUCTION

Agriculture, which remains crucial for food production, raw materials, and worldwide employment, benefits greatly from technological advancements. Despite its importance, the sector faces significant challenges, such as water scarcity, wildlife infiltration, and poor irrigation [1]. Advances on the Internet of Things (IoT) and solar energy have made it possible to develop data-driven, energy-efficient farming systems [2]. In response to ongoing agricultural challenges, the Enhanced Smart Solar-Powered Crop Protection and Irrigation System with IoT is introduced to integrate technological solutions with conventional agricultural methods, with the goal of transforming the farming systems.

The system integrates real-time monitoring, animal detection, and automated irrigation to enhance crop yield, optimize water usage, and improve overall farm efficiency. The system uses a camera to continuously monitor crops, allowing early detection of wild animal intrusions. The system supports sustainable operation while reducing reliance on external power sources using solar energy. Furthermore, the IoT-enabled user interface [3] allows farmers to remotely monitor crop conditions and manage irrigation schedules, contributing to efficient water conservation. The system is aimed to address agricultural needs by enhancing productivity, conserving resources, and promoting sustainable farming practices that benefit both farmers and the environment.

## METHODOLOGY

Figure 1 illustrates the block diagram of the system, which represents a fully automated and IoT-based monitoring solution utilizing the ESP32 microcontroller. The system detects motion using a PIR sensor and activates the buzzer upon detection, while the camera module captures an image and transmits it to the farmer's mobile device using IoT. The water pump is activated to irrigate crops when the soil moisture level falls below a predefined threshold value. Once the moisture level reaches the threshold, the pump is turned off and will resume operation when the sensor detects a decrease in moisture level.

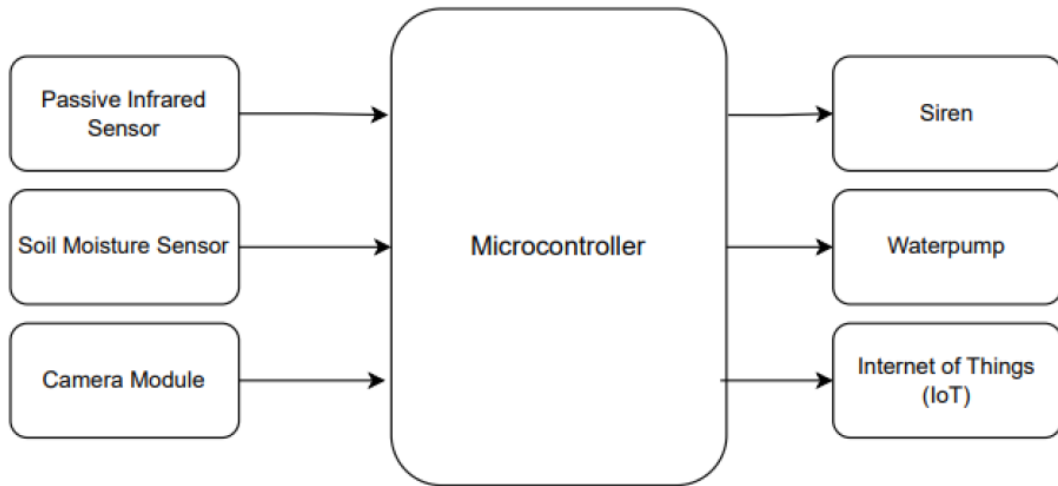

Figure 1. Block diagram of smart crop protection and irrigation system using IoT.

## RESULT AND DISCUSSION

Figure 3 shows the response of the system upon detecting motion where the captured image is sent to the Telegram Application. Figure 4 presents the available solar power generated by the solar panel while Table 1 summarizes the power consumption of the components used in the system.



Figure 3. Result of telegram application

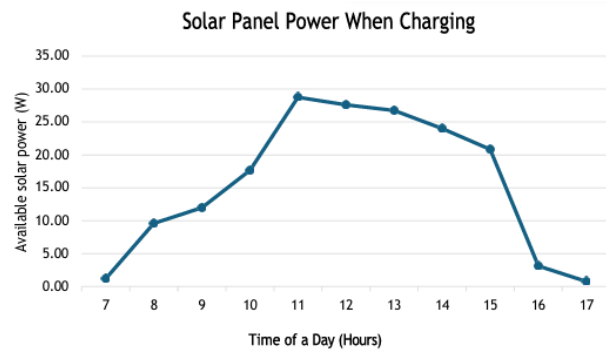

Figure 4. Solar output power measurement

Table 1. Power consumption of project

Component	Voltage (V)	Current (A)	Power (W)
Siren	12	1.50	18.00
Water pump	12	0.30	3.60
ESP32	5	0.10	0.50
ESP32-CAM	5	0.15	0.75

## CONCLUSION

The proposed system integrates solar energy, IoT technology, and automated irrigation to address critical challenges in modern agriculture, including water scarcity and crop protection. Future enhancements may include the integration of GSM modules alongside Wi-Fi connectivity, enabling the system to function effectively in areas with limited internet access

## **REFERENCES**

- [1] S. Pradeep, G. Vyshnavi, M. Tejaswini, P. Vaishnavi, and Y. Indhu, "IoT Based Remote Operated Smart Irrigation System for Enhancing the Crop Yield," in 5th IEEE International Conference on Cybernetics, Cognition and Machine Learning Applications, 2023, pp. 287–291.
- [2] M. S. Sahitya, L. Vinay, B. P. Sah, P. Srilatha, and B. S. Kiruthika Devi, "An Investigation on Smart Crop Protection System Utilizing Internet of Things," in 2022 8th International Conference on Signal Processing and Communication, pp. 43–48, 2022.
- [3] L. Sarala, C. Swapna, S. Alekhya, and S. Nausheen, "Smart Farming Farm Guard: Crop Protection System," in 10th International Conference on Advanced Computing and Communication Systems, 2024, pp. 1613–1616.

# POWERED SOLAR WATER IRRIGATION FOR CHILLI PLANTATION

Muhammad Abdul Hayei Abdul Razak, Siti Aishah binti Che Kar  
*Faculty of Electrical Engineering,  
Universiti Teknologi MARA Cawangan Terengganu,  
Kampus Dungun, 23000 Dungun, Malaysia.  
[sitia2500@uitm.edu.my](mailto:sitia2500@uitm.edu.my)*

**Abstract:** This research presents the development of a Powered Solar Water Irrigation system specifically designed for efficient and sustainable chili cultivation. By integrating renewable energy sources, the system addresses critical agricultural challenges such as real-time monitoring of environmental parameters including soil moisture, temperature and water level. The system also automates the important irrigation task to optimize water use and ensure ideal conditions for chili plant growth. The setup uses solar panels to power sensors, microcontrollers and actuators that are integrated through specialized technology in arduino UNO. This allows for precise irrigation management, reducing water wastage and reducing operating costs. Arduino uno provides real-time data and alerts, enabling timely intervention and better control over the irrigation process. The use of solar energy minimizes dependence on conventional energy sources, thereby reducing the carbon footprint and promoting environmentally friendly agricultural practices. The results of the study show that improved resource efficiency, better environmental control, and a significant reduction in human labor, contribute to sustainable chili production.

**Keywords:** Soil Moisture Sensor, Arduino, Solar Powered

## INTRODUCTION

Powered Solar Water Irrigation for Chili Farms is an innovative solution for sustainable agriculture. The system uses solar energy to power smart irrigation, ensuring efficient water use and optimal conditions for chili crops. The technology inside the integrated Arduino UNO monitors parameters such as soil moisture, temperature and pH in real time, automating irrigation to reduce water wastage and improve plant health. By minimizing reliance on conventional energy, the system reduces operating costs and reduces the carbon footprint. Scaled for small farms, this eco-friendly approach increases productivity, saves resources and encourages sustainable consumption, addressing global challenges in food security and environmental conservation.

## METHODOLOGY

For this system, Arduino UNO is a main component to connect all sensors and components. This project uses soil moisture sensor to measure soil underground. After that, this project uses LED to show about condition of water pump that turn on or off. For the output is a water pump to supply water to the plant. Lastly, LCD to show value soil underground detected by soil moisture sensor. A solar-powered irrigation system integrates various components for efficient water management. The soil moisture sensor measures soil water levels and helps regulate irrigation, while the LCD (16×2 I2C) displays real-time moisture readings. The Arduino UNO microcontroller acts as the central hub, processing sensor data, controlling the water pump, and displaying moisture values on the LCD. The water pump automatically activates upon receiving a signal from the Arduino. A solar power system with a battery supplies renewable energy to all components, reducing reliance on traditional power sources. Additionally, a red LED indicates when the pump is off, while a green LED lights up when the pump is active. The block diagram of this project is shown in Figure 1.

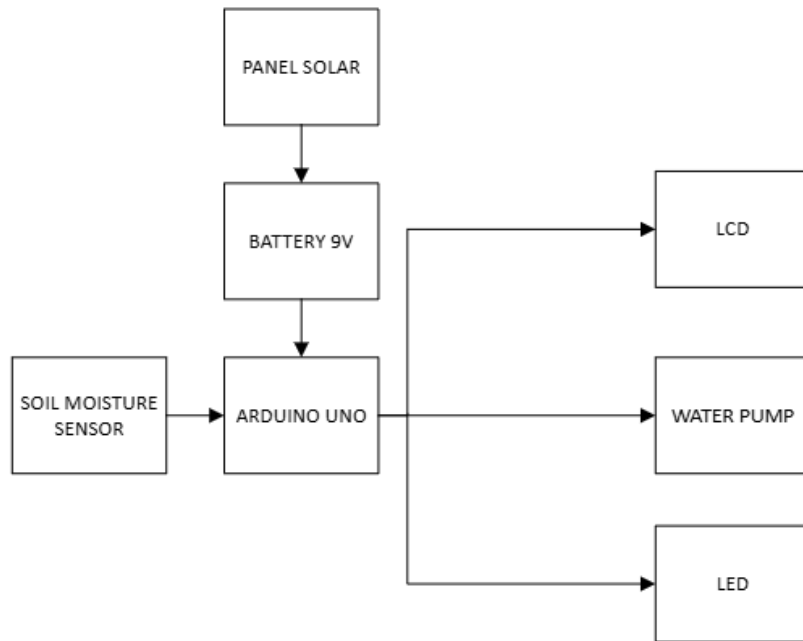

Figure 1. Block diagram of the project

## RESULT AND DICUSSION

Flow chart of this project shown in Figure 2. The system starts by initializing all components. The Arduino UNO microcontroller sends data to the soil moisture sensor, which detects the water level in the soil. The detected moisture value is displayed on the LCD screen. If the moisture level is below 400 (DRY), the water pump turns on; if above 400 (WET), the pump turns off. The LED indicators provide visual feedback when the pump is on, the green LED lights up while the red LED turns off, and vice versa when the pump is off. Once the system completes its current operation, it prepares for the next cycle.

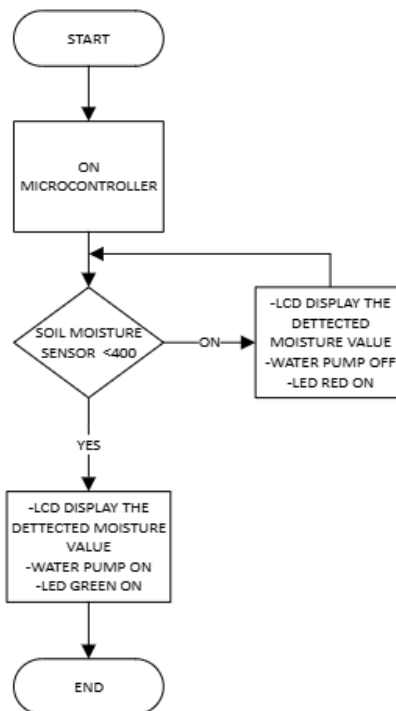

Figure 2. Flow chart diagram of the project

## CONCLUSION

This project details the effective creation of a solar-powered water irrigation system that incorporates Arduino UNO technology. The results demonstrate that the system automates critical tasks, such as tracking subsurface water levels. The project's main contributions are lowering the need for human labour, encouraging sustainable agricultural methods, and powering the system with renewable solar energy. Nevertheless, the system has a limited sunlight limit and depends on each component being connected neatly. These were the project's two main obstacles. Notwithstanding these difficulties, the project achieved its goals and offered a strong basis for creating an intelligent and environmentally friendly water irrigation system.

## REFERENCES

- [1] Valducci, "Drip Irrigation on Chilli Peppers," Valducci, March 29, 2022. [Online]. Available: <https://valducci.com>.
- [2] Ajeet Singh, S.K. Sharma, Rahul Chopra, Virendra Singh, R.A Kaushik, R.S. Rathore and Jain, H.K. 2017. Impact of Drip Fertigation on Yield and Nutrients Uptake by Chilli (*Capsium annuum* L.)*Int.J.Curr.Microboil.App.Sci.* 6(8): 1409-1416.
- [3] "Chilli Cultivation Information Guide," Asia Farming. [Online]. Available: <https://www.asiafarming.com/chilli-cultivation>. [Accessed: 27-Jan-2025].
- [4] "Studies on Irrigation and Fertigation Management on Chilli," KrishiKosh. [Online]. Available:<https://krishikosh.egranth.ac.in/server/api/core/bitstreams/171fe4d1-5fc7-4def-8b31-92ddac4c35cd/content>. [Accessed:27-Jan02025].
- [5] "Correctly Watering Chilli Plants," Chilli Kits. [Online]. Available: <https://www.chillikits.co.uk/correctly-watering-chilli-plants>. [Accessed: 27- Jan-2025].
- [6] J. Singh and A. Sharma, "Solar Powered IoT-Based Smart Irrigation System," Proceedings of the International Conference on Intelligent Computing and Communication (ICICC), 2019.